

承认书

Specification for approval

客户名称：

Customer:

产品型号：GP-1WW3-11120-P33T

Product Part No.:

制定人：



日期：

Issued By:

Date:

审核：

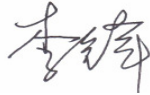

日期：

Approved By:

Date:

客户回签：

日期：

Custer Confirmation:

Date:

SHENZHEN CUANGMAI ELECTRONIC CO., LTD.

地址 (Add): 宝安福永永福路与重庆路交叉口金港工业园 B 栋 4-5 楼

电话 (Tel): 86-755-23499599

传真 (Fax): 86-755-23497717

Features:

- More energy efficient than incandescent and most halogen lamps
- low voltage operation
- Instant light
- Long operating life
- Anti UV



Applications:

- Indoor lighting:
spot light, ceiling light, bulb.....
- Architectural and landscape lighting:
down light, wall lamp, garden light
- Roadway lighting:
Street light, garden light, tunnel light
- Display lighting:

产品特征:

- 较传统灯的高能效
- 低电压工作
- 瞬间点亮
- 超长工作时间
- 防紫外



产品应用:

- 室内照明: 射灯,
天花灯, 球泡灯等
- 建筑及景观照明:
投光灯, 洗墙灯, 园林灯
- 道路照明:
路灯, 庭院灯, 隧道灯
- 展示照明

■ Package Dimensions 封装外形尺寸

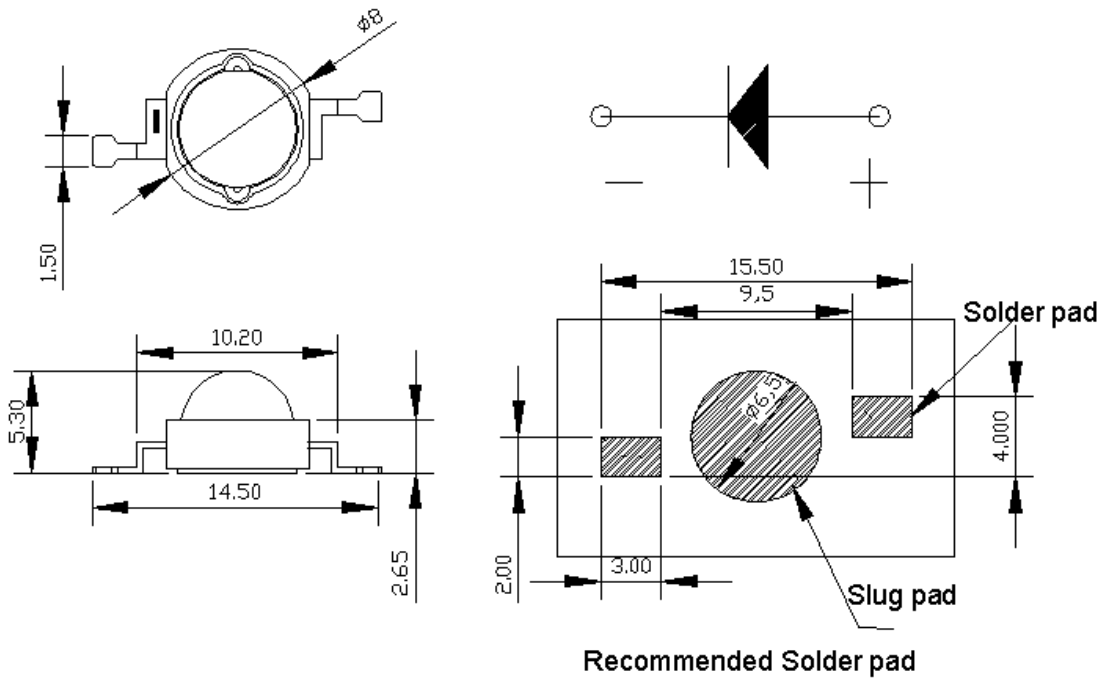

Notes: All dimensions in mm tolerance is $\pm 0.1\text{mm}$ unless otherwise noted.
除非另有说明，以上尺寸以 mm 为单位，公差在 $\pm 0.1\text{mm}$ 。

■ Absolute Maximum Ratings 极限参数 (Ta=25°C)

Parameter	Symbol	Rating	Unit
DC Forward Current 正向电流	I_F	350	mA
Peak pulse Current* 脉冲电流	I_{FP}	1000	mA
Reverse Voltage 反向电压	V_R	5	V
Power Dissipation 功率	P_D	1	W
Operating Temperature Range 工作温度	T_{OPR}	-30 ~ +75	°C
Storage Temperature Range 储存温度	T_{STG}	-40 ~ +85	°C
LED Junction Temperature 结点温度	T_J	125	°C

Notes: 1. 1/10 Duty Cycle 0.1ms Pulse Width. (脉冲宽度 0.1ms, 占空比 1/10)

■ Electrical/Optical Characteristics--White (At TA=25°C) 光电特性参数

Parameter	Symbol	Conditions	Min	Avg.	Max	Units
Forward Voltage 正向压降	V_F	$I_F=350mA$	3.00	--	3.40	V
Thermal Resistance Junction To Board 热阻	$R_{\theta J-B}$	$I_F=350mA$	--	10	--	°C/W
Luminous Flux 光通量	Φ_v	$I_F=350mA$	120		130	lm
Color Temperature 色温	CCT	$I_F=350mA$	3000		3200	K
CRI 显色指数	Ra	$I_F=350mA$	60	--	--	--
Temperature Coefficient of Forward Voltage 正向压降之温度系数	$\Delta V_F/\Delta T$	$I_F=350mA$	--	-2	--	mV/°C
Reverse Current 反向漏电流	I_R	$V_R=5V$	--	--	10	μA
Viewing Angle ^[1] 发光角度	$2\theta_{1/2}$	$I_F=350mA$	--	140	--	Deg

■ part No. Description 产品型号说明

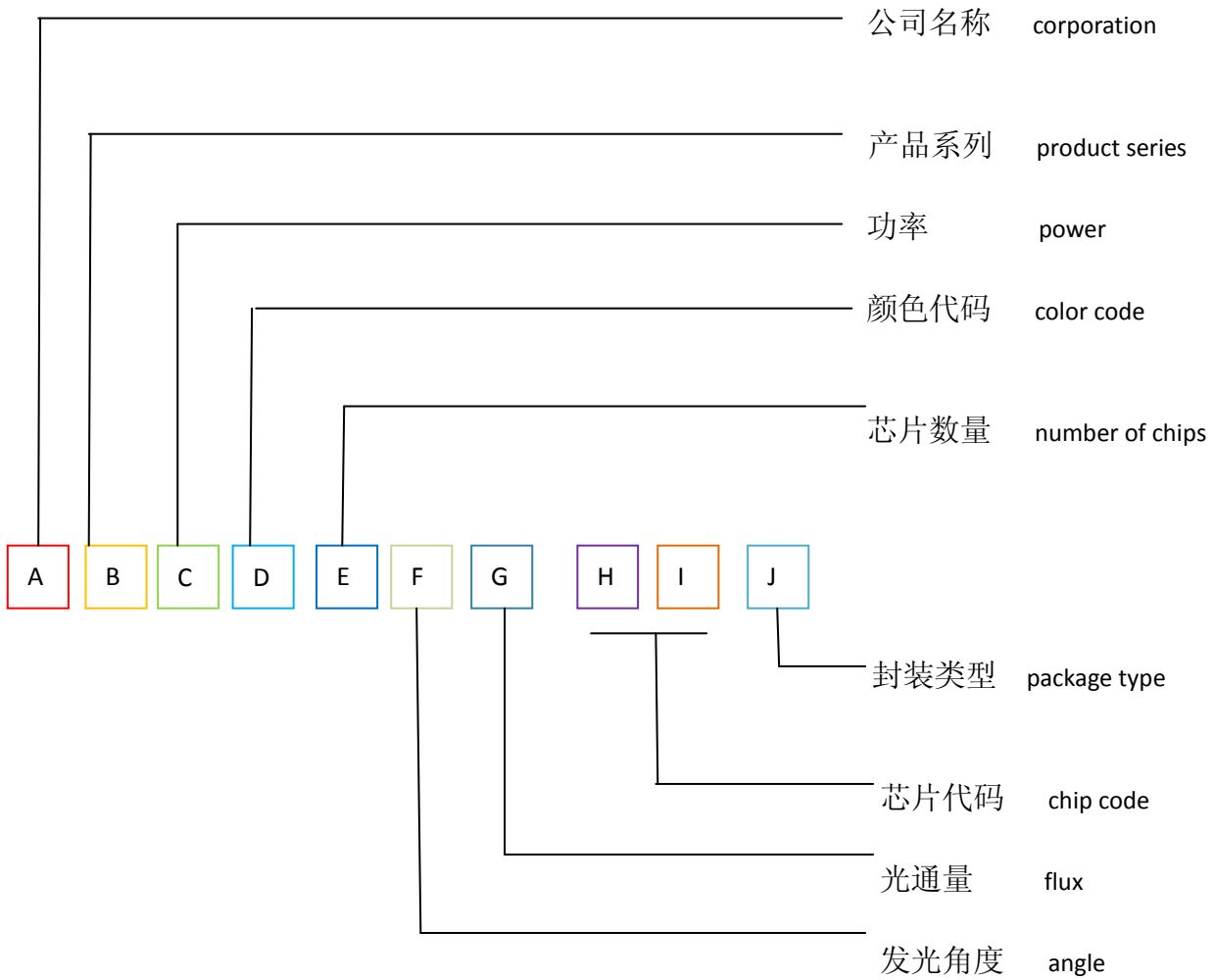

1. A : G 代表光脉 GM
2. B : P 代表大功率 (仿流明) high power O 代表大功率 (仿欧斯朗) OSRAM
3. C : 功率编码 power code

编码 code	功率 power
0	0.5w
1	1w
3	3w
5	5w

4. D : 颜色编码 color code

紫光 purple		蓝光 blue		绿光 green		黄绿光 yellow green	
编码	波段	编码	波段	编码	波段	编码	波段
P1	360-370	B1	440-450	G1	480-490	E1	540-550
P2	370-380	B2	450-460	G2	490-500	E2	550-555
P3	380-390	B3	460-465	G3	500-510	E3	555-560
P4	390-400	B4	465-470	G4	510-515	E4	560-565
P5	400-410	B5	470-480	G5	515-520	E5	570-575
P6	410-420	B6		G6	520-525	E6	575-580
P7	420-430	B7		G7	525-530	E7	
P8	430-440	B8		G8	530-540	E8	
P9		B9		G9		E9	

黄光 yellow		橙红光 orange		红光 red	
编码	波段	编码	波段	编码	波段
Y1	580-585	C1	600-605	R1	615-620
Y2	585-587.5	C2	605-610	R2	620-625
Y3	587.5-590	C3	610-615	R3	625-630
Y4	590-592.5	C4		R4	630-640
Y5	592.5-595	C5		R5	640-650
Y6	595-597.5	C6		R6	650-660
Y7	597.5-600	C7		R7	730
Y8		C8		R8	850
Y9		C9		R9	940

白光 white	
W3	5000k 以下色温 CCT<5000K
W6	5000k 以上色温 CCT>5000k

5. E : 芯片数量 number of chips 1 代表 1pcs 芯片, 2 代表 2pcs 芯片.....

6. F : 发光角度编码 viewing angle code

编码	角度
0	120
1	140
3	30
5	90/160
6	60
7	175
9	90

7. G : 光通量 flux
020 代表 20-30lm, 100 代表 100-110lm

8. H I : 芯片代码 chip code

9. J : M 代表硅胶模腔封装 (silicone encapsulation), T 代表透镜封装 (lens encapsulation), B 代表带板 (board)
P 代表平面封装 (plane)



光脉科技

lighting the world

Technical Data Sheet

www.szgmlcd.com

Color & binning 色区分级

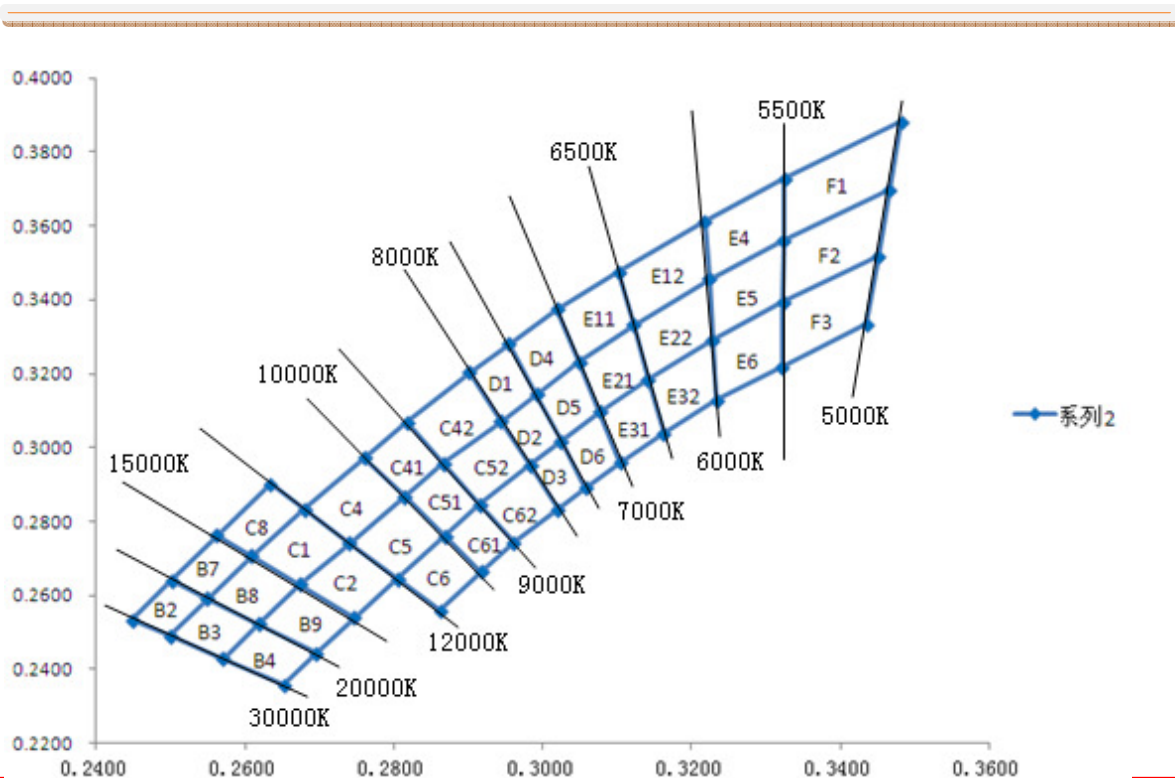
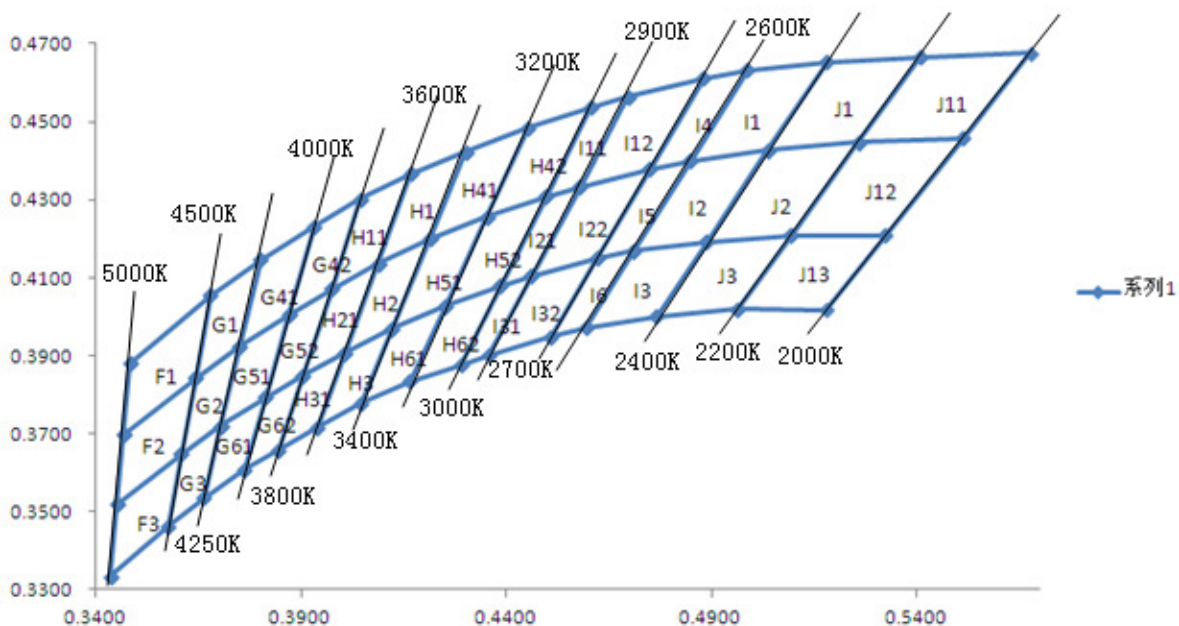

J11	0.5409	0.4666	J12	0.5258	0.4447	J13	0.5093	0.4209
	0.5677	0.4675		0.5513	0.4458		0.5323	0.4208
	0.5513	0.4458		0.5323	0.4208		0.5179	0.4018
	0.5258	0.4447		0.5093	0.4209		0.4963	0.4020
J1	0.5180	0.4653	J2	0.5036	0.4426	J3	0.4888	0.4192
	0.5409	0.4666		0.5258	0.4447		0.5093	0.4209
	0.5258	0.4447		0.5093	0.4209		0.4963	0.4020
	0.5036	0.4426		0.4888	0.4192		0.4766	0.4001
I1	0.4988	0.4632	I2	0.4849	0.4399	I3	0.4711	0.4169
	0.5180	0.4653		0.5036	0.4426		0.4888	0.4192
	0.5036	0.4426		0.4888	0.4192		0.4766	0.4001
	0.4849	0.4399		0.4711	0.4169		0.4593	0.3972
I4	0.4880	0.4611	I5	0.4750	0.4379	I6	0.4622	0.4150
	0.4988	0.4632		0.4849	0.4399		0.4711	0.4169
	0.4849	0.4399		0.4711	0.4169		0.4593	0.3972
	0.4750	0.4379		0.4622	0.4150		0.4509	0.3948
I12	0.4697	0.4563	I22	0.4579	0.4334	I32	0.4461	0.4104
	0.4880	0.4611		0.4750	0.4379		0.4622	0.4150
	0.4750	0.4379		0.4622	0.4150		0.4509	0.3948
	0.4579	0.4334		0.4461	0.4104		0.4357	0.3901
I11	0.4605	0.4536	I21	0.4496	0.4308	I31	0.4386	0.4080
	0.4697	0.4563		0.4579	0.4334		0.4461	0.4104
	0.4579	0.4334		0.4461	0.4104		0.4357	0.3901
	0.4496	0.4308		0.4386	0.4080		0.4289	0.3877
H42	0.4454	0.4484	H52	0.4353	0.4257	H62	0.4251	0.4028
	0.4605	0.4536		0.4496	0.4308		0.4386	0.4080
	0.4496	0.4308		0.4386	0.4080		0.4289	0.3877
	0.4353	0.4257		0.4251	0.4028		0.4164	0.3834
H41	0.4302	0.4423	H51	0.4214	0.4200	H61	0.4122	0.3969
	0.4454	0.4484		0.4353	0.4257		0.4251	0.4028
	0.4353	0.4257		0.4251	0.4028		0.4164	0.3834
	0.4214	0.4200		0.4122	0.3969		0.4047	0.3779

H1	0.4167	0.4366	H2	0.4087	0.4136	H3	0.4007	0.3908
	0.4302	0.4423		0.4214	0.4200		0.4122	0.3969
	0.4214	0.4200		0.4122	0.3969		0.4047	0.3779
	0.4087	0.4136		0.4007	0.3908		0.3940	0.3717
H11	0.4045	0.4301	H21	0.3974	0.4072	H31	0.3904	0.3850
	0.4167	0.4366		0.4087	0.4136		0.4007	0.3908
	0.4087	0.4136		0.4007	0.3908		0.3940	0.3717
	0.3974	0.4072		0.3904	0.3850		0.3845	0.3659
G42	0.3932	0.4232	G52	0.3870	0.4005	G62	0.3812	0.3793
	0.4045	0.4301		0.3974	0.4072		0.3904	0.3850
	0.3974	0.4072		0.3904	0.3850		0.3845	0.3659
	0.3870	0.4005		0.3812	0.3793		0.3761	0.3608
G41	0.3800	0.4146	G51	0.3750	0.3923	G61	0.3704	0.3720
	0.3932	0.4232		0.3870	0.4005		0.3812	0.3793
	0.3870	0.4005		0.3812	0.3793		0.3761	0.3608
	0.3750	0.3923		0.3704	0.3720		0.3662	0.3536
G1	0.3679	0.4055	G2	0.3642	0.3843	G3	0.3608	0.3648
	0.3800	0.4146		0.3750	0.3923		0.3704	0.3720
	0.3750	0.3923		0.3704	0.3720		0.3662	0.3536
	0.3642	0.3843		0.3608	0.3648		0.3576	0.3463
F4	0.3482	0.3881	F5	0.3466	0.3698	F6	0.3451	0.3519
	0.3679	0.4055		0.3642	0.3843		0.3608	0.3648
	0.3642	0.3843		0.3608	0.3648		0.3576	0.3463
	0.3466	0.3698		0.3451	0.3519		0.3435	0.3335

F1	0.3325	0.3728	F2	0.3324	0.3560	F3	0.3323	0.3394
	0.3482	0.3881		0.3466	0.3698		0.3451	0.3519
	0.3466	0.3698		0.3451	0.3519		0.3435	0.3335
	0.3324	0.3560		0.3323	0.3394		0.3322	0.3219
E4	0.3218	0.3613	E5	0.3224	0.3456	E6	0.3229	0.3291
	0.3325	0.3728		0.3324	0.3560		0.3323	0.3394
	0.3324	0.3560		0.3323	0.3394		0.3322	0.3219
	0.3224	0.3456		0.3229	0.3291		0.3234	0.3129
E12	0.3102	0.3475	E22	0.3122	0.3332	E32	0.3142	0.3184

	0.3218	0.3613		0.3224	0.3456		0.3229	0.3291
	0.3224	0.3456		0.3229	0.3291		0.3234	0.3129
	0.3122	0.3332		0.3142	0.3184		0.3163	0.3038
E11	0.3020	0.3374	E21	0.3049	0.3232	E31	0.3077	0.3096
	0.3102	0.3475		0.3122	0.3332		0.3142	0.3184
	0.3122	0.3332		0.3142	0.3184		0.3163	0.3038
	0.3049	0.3232		0.3077	0.3096		0.3104	0.2960
D4	0.2955	0.3281	D5	0.2992	0.3143	D6	0.3025	0.3018
	0.3020	0.3374		0.3049	0.3232		0.3077	0.3096
	0.3049	0.3232		0.3077	0.3096		0.3104	0.2960
	0.2992	0.3143		0.3025	0.3018		0.3058	0.2892

D1	0.2902	0.3203	D2	0.2944	0.3070	D3	0.2983	0.2952
	0.2955	0.3281		0.2992	0.3143		0.3025	0.3018
	0.2992	0.3143		0.3025	0.3018		0.3058	0.2892
	0.2944	0.3070		0.2983	0.2952		0.3021	0.2833
C42	0.2818	0.3069	C52	0.2867	0.2957	C62	0.2916	0.2846
	0.2902	0.3203		0.2944	0.3070		0.2983	0.2952
	0.2944	0.3070		0.2983	0.2952		0.3021	0.2833
	0.2867	0.2957		0.2916	0.2846		0.2961	0.2744
C41	0.2761	0.2972	C51	0.2815	0.2868	C61	0.2869	0.2761
	0.2818	0.3069		0.2867	0.2957		0.2916	0.2846
	0.2867	0.2957		0.2916	0.2846		0.2961	0.2744
	0.2815	0.2868		0.2869	0.2761		0.2918	0.2665
C4	0.2680	0.2833	C5	0.2740	0.2742	C6	0.2805	0.2645
	0.2761	0.2972		0.2815	0.2868		0.2869	0.2761
	0.2815	0.2868		0.2869	0.2761		0.2918	0.2665
	0.2740	0.2742		0.2805	0.2645		0.2862	0.2559
C8	0.2562	0.2762	C1	0.2609	0.2706	C2	0.2673	0.2629
	0.2634	0.2902		0.2680	0.2833		0.2740	0.2742
	0.2680	0.2833		0.2740	0.2742		0.2805	0.2645
	0.2609	0.2706		0.2673	0.2629		0.2747	0.2540
B7	0.2502	0.2641	B8	0.2549	0.2592	B9	0.2618	0.2522
	0.2562	0.2762		0.2609	0.2706		0.2673	0.2629
	0.2609	0.2706		0.2673	0.2629		0.2747	0.2540
	0.2549	0.2592		0.2618	0.2522		0.2696	0.2443

■ Typical Optical/Electrical Characteristics Curves 典型光电参数曲线

($T_a=25^\circ\text{C}$ Unless Otherwise Noted)

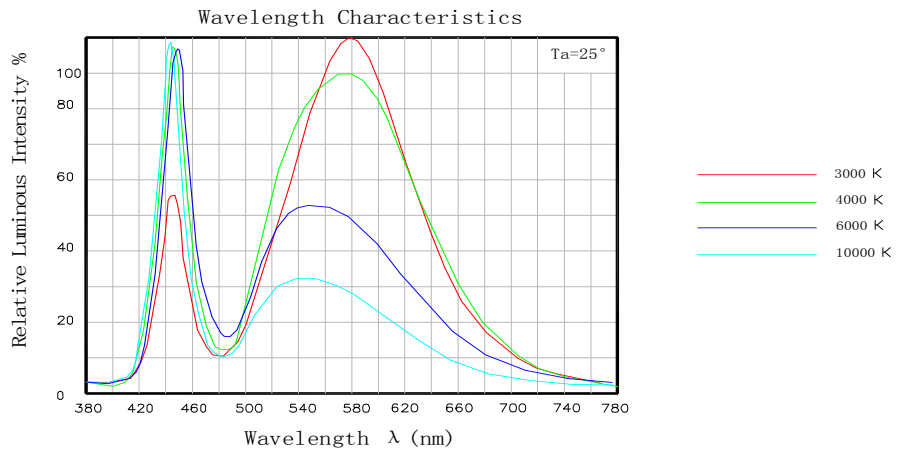
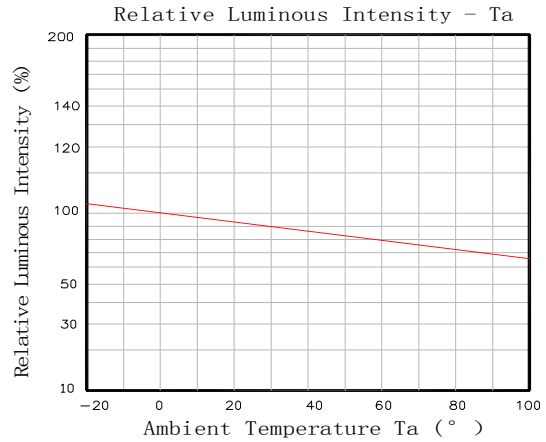
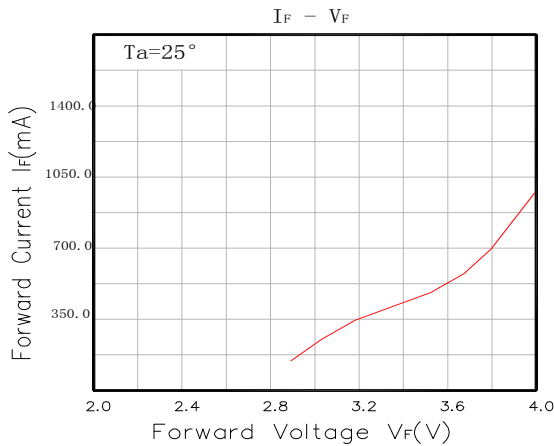
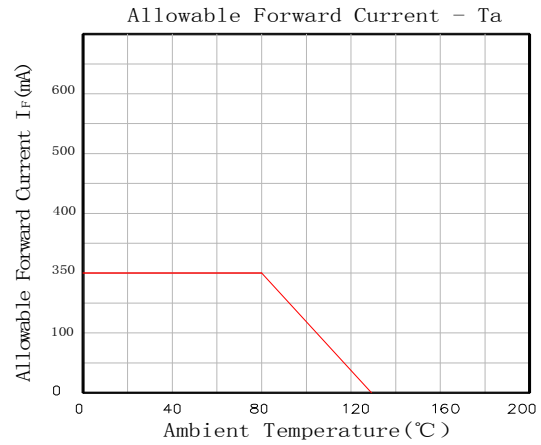
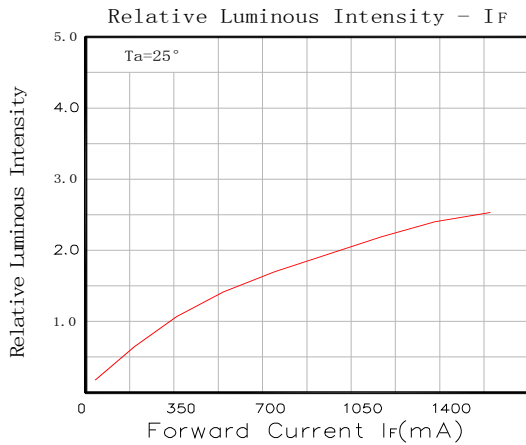

■ Radiation Diagram 角度图

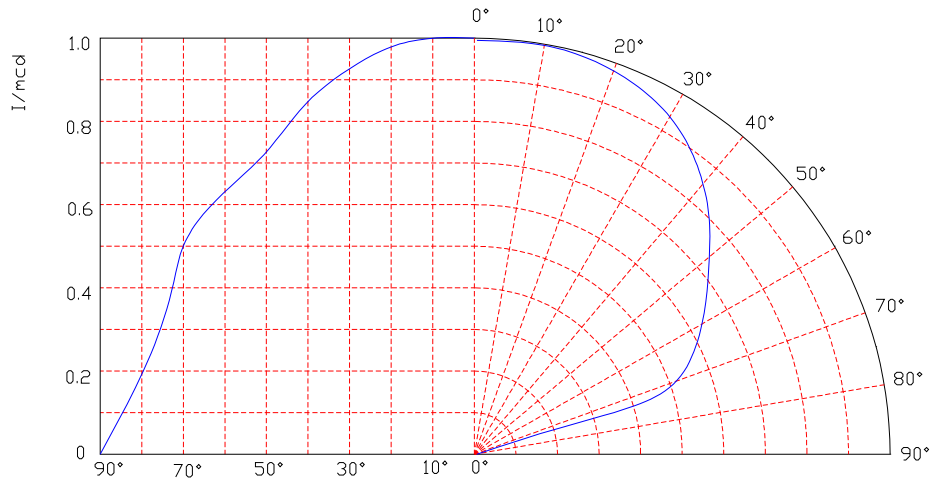

■ Packing Standard 包装标准

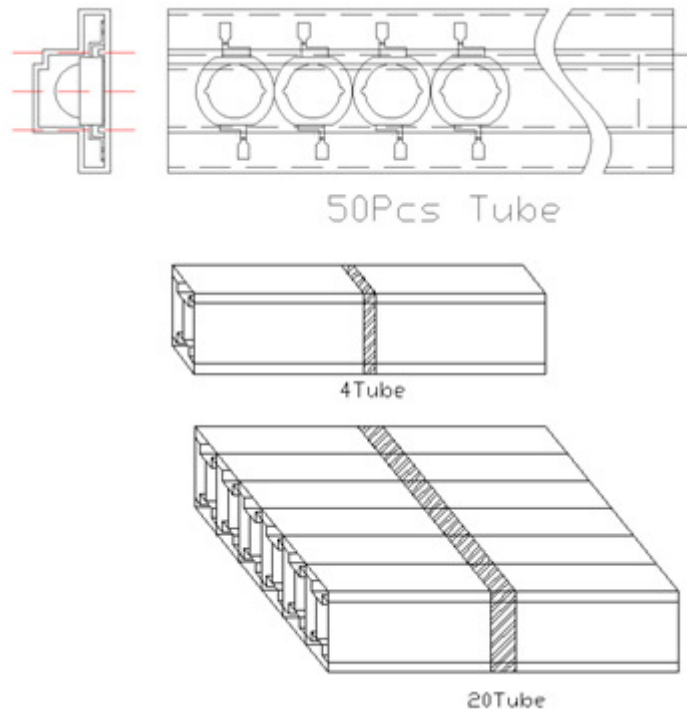

■ Reliability test standards 可靠性实验标准

类别 Type	测试项目 Test Item	参考标准 REF. Standard	测试条件 Test condition	持续时间 Duration	取样数 Sample count	允收数 Accept
环境 测试	温度循环 Temperature Cycle	JESD22-A104-A	-40℃~25℃~100℃~25℃ 30min,5min,30min,5min	循环 100 次/ 100 cycles	22	0/22
	冷热冲击 Thermal shock	JESD22-A106	-40℃~100℃ 30min, 30min	循环 100 次/ 100 cycles	22	0/22
	高温储存 High Temperature Storage	JEITA ED-4701 200 201	TA=100℃ ± 5℃	1000 Hrs	22	0/22
	低温储存 Low Temperature Storage	JEITA ED-4701 200 202	TA=-40℃ ± 5℃	1000 Hrs	22	0/22
	高温 / 高湿 储存 Humidity Heat Storage	JIS C 7021 (1977)B-11	Ta=60℃ RH=85%	1000Hrs	22	0/22
寿命 试验	寿命测试 Life test	JESD22-A108-A	Ta=25℃ If=350mA	1000Hrs	22	0/22
	高温/高湿寿命测试 High humidity Heat life test	JESD22-A101	Ta=60℃ RH=85% If=350mA	1000Hrs	22	0/22
破坏 性试 验	耐焊性 Resistance to soldering Heat	JESD22-A113	IR soldering 245℃/10sec	1 time	20	0/22

Precautions for use

使用说明

1. Storage 储存

(1) The best Storage environment: temperature :5°C~30°C , Humidity:40% -80%HR.
最佳储存条件在 5°C~30°C, 40% -80%HR

(2) LED store after six months to be re-spectral color separation, to prevent the LED optical properties change.

储存六个月之后需重新分光分色后使用, 防止光电参数发生变化。

2. Production and application 生产应用

(1) need wear gloves when contact with led to prevent oxidation.

手接触灯珠时须戴手套。

(2) ESD protection to be good

生产过程中需做好防静电措。

(3) soldering: the pc type can use soldering iron, (the best temperature is 300°C/3sec) also can use Temperature Platform (150°C/30sec,max) the Silica encapsulation and high temperature PC lens package can also be used for reflow soldering.

焊接: pc 型可以采用烙铁手工焊接, 条件为 300°C/3sec, 也可以采用低温锡膏加热平台焊接, 温度不超过 150°C/30sec, 硅胶封装和高温 PC 透镜封装的还可以采用回流焊接。

(4) about Package-type silicone , It is recommended to bake before soldering when the pack is unsealed after 24h. The conditions are as following: 80°C 4-6h.

对于硅胶透镜产品需过回流焊的话, 产品开封 24h 内需使用完毕, 否则需 80°C 烘烤 4-6h 后再过回流焊。

(5) must have a good heat sinking, the temperature of the heat sink must be below 65 degree .

做好散热措施, 热沉温度须低于 65。

3. Relow temp/time 回流焊温度曲线

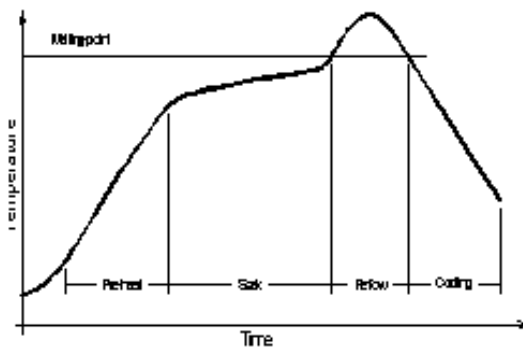

焊接剂 = 低温无铅锡	焊接剂 = 无铅锡
温度上升斜率= 4°C/s 最大	温度上升斜率=4°C/s 最大
预热温度 = 100°C ~150°C	预热温度 = 150°C ~180°C
预热时间 = 60s 最大	预热时间 = 90s 最大.
温度下降斜率为 6°C/s 最大	温度下降斜率为 6°C/s 最大
峰值温度 = 180°C 最大	峰值温度 = 220°C 最大
在峰值温度±5°C时间不能超过 10s	在峰值温度±5°C时间不能超过 10s
超过 160°C 的温度的时间不能超过 60s.	超过 160°C 的温度的时间不能超过 60s.